

CLASS WITH THE LANGUAGE ASSISTANT

- **Proyectar con el cañón fotos de los planetas y describirlos ella en inglés.**
- **Lanzar preguntas a ellos o usar la fotocopia The Planets and Moons of our Solar System**

The Planets and Moons of Our Solar System

This activity can be used in conjunction with the StarChild Solar System Level 1 information. This activity can engage your students not only in learning about the solar system, but in practicing important language arts skills. Besides being a good skill builder for learners with limited reading skills, the students will also practice their understanding of concepts and words such as first, second, third, etc.; closest, farthest; more than, less than. Basic math skills such as counting and ordering are also involved.

1. This planet has one more moon than Earth. The planet is called _____. It has _____ moons.
 2. This planet has the most moons. The planet is called _____. It has _____ moons.
 3. This planet is closest to the Sun. The planet is called _____. It has _____ moons.
 4. This planet has the second most moons. The planet is called _____. It has _____ moons.
 5. This planet is third from the Sun. The planet is called _____. It has _____ moon.
 6. This planet is the farthest planet from the Sun. The planet is called _____. It has _____ moons.
 7. This planet has the same number of moons as Mercury has. The planet is called _____. It has _____ moons.
 8. This is the closest to Neptune. The planet is called _____. It has _____ moons.
- Se puede trabajar la descripción de cada planeta (tamaño, color), su posición dentro del sistema solar y se plantean comparaciones entre ellos. Para casa se puede proponer la elaboración de un cuadro comparativo como el siguiente:

Planet	Inner or outer	Between ... and ...	Size	Rocky or gaseous	Colour	Other features

TALKING ABOUT SOLAR SYSTEM.

You show a picture of the [eight planets](#) of the Solar System and you can say their names, starting on the nearest one to the [Sun](#) (Mercury, Venus, Earth, Mars, Jupiter, Saturn, Uranus, Neptune and Pluto). Maybe somebody can ask about Pluto but today Pluto is considered a dwarf planet. The students can repeat the pronunciation of the names.

We can talk about their position and review ordinal numbers:

- Which planet is the first? (Mercury)
- Which planet occupies the second position? (Venus)
- And the fifth planet? (Jupiter)
- And the eighth planet? (Neptune)
- Which planet is the fourth?
- Which planet....
- Which position does Neptune occupy?
- Which position...

We can also compare their position (using comparatives and superlative):

- Which is the farthest planet to the Sun? (Neptune)
- Which one is the nearest to the Sun? (Mercury)
- Which planets are near to the Earth? (Venus and Mars)
- Which four planets are the inner planets? (Mercury, Venus, Earth, Mars)
- Which four planets are the outer planets? (Jupiter, Saturn, Uranus, Neptune, Pluto)
-

Then we can talk about the size of the planets?

- Which is the largest planet? (Jupiter)
- Which is smallest one? (Pluto)
- What size is Mars? (Small) And the Earth? (Small) And Saturn? (Big)

- Which planets are bigger, outer planets or inner planets? (The outer planets are giant)

After that we can talk about the colour and the appearance of the planet.

- Which planet is red? (Mars)
- Which planets are bluish coloured? (Uranus and Neptune. The Earth is blue because of the oceans)
- Which planet has rings around it? (Jupiter)
- Which planet displays bands of colours? (Jupiter)
- What colour is Mars? (Red)
- How can you recognise Jupiter? (Colour bands) And Saturn? (Rings)
- Describe Uranus: location, size and colour.
- Describe Mercury: location, size and colour.

Read the definitions, then label the diagram below.

Definitions

Sun - The Sun is a star at the center of our Solar System.

Jupiter - Jupiter is the fifth planet from the Sun. This gas giant is the largest planet.

Mercury - Mercury is the planet closest to the Sun.

Saturn - Saturn is the sixth planet from the Sun. This gas giant has large, beautiful rings.

Venus - Venus is the second planet from the Sun. It is the hottest planet.

Uranus - Uranus is a gas giant and is the seventh planet from the Sun.

Earth - Earth is the third planet from the Sun and the planet we live on.

Neptune - Neptune is a gas giant and is usually the eighth planet from the Sun.

Mars - Mars is a red planet and the fourth planet from the Sun.

Pluto - Pluto is a dwarf planet that is usually the farthest planet from the Sun. It is smaller than the 8 planets.

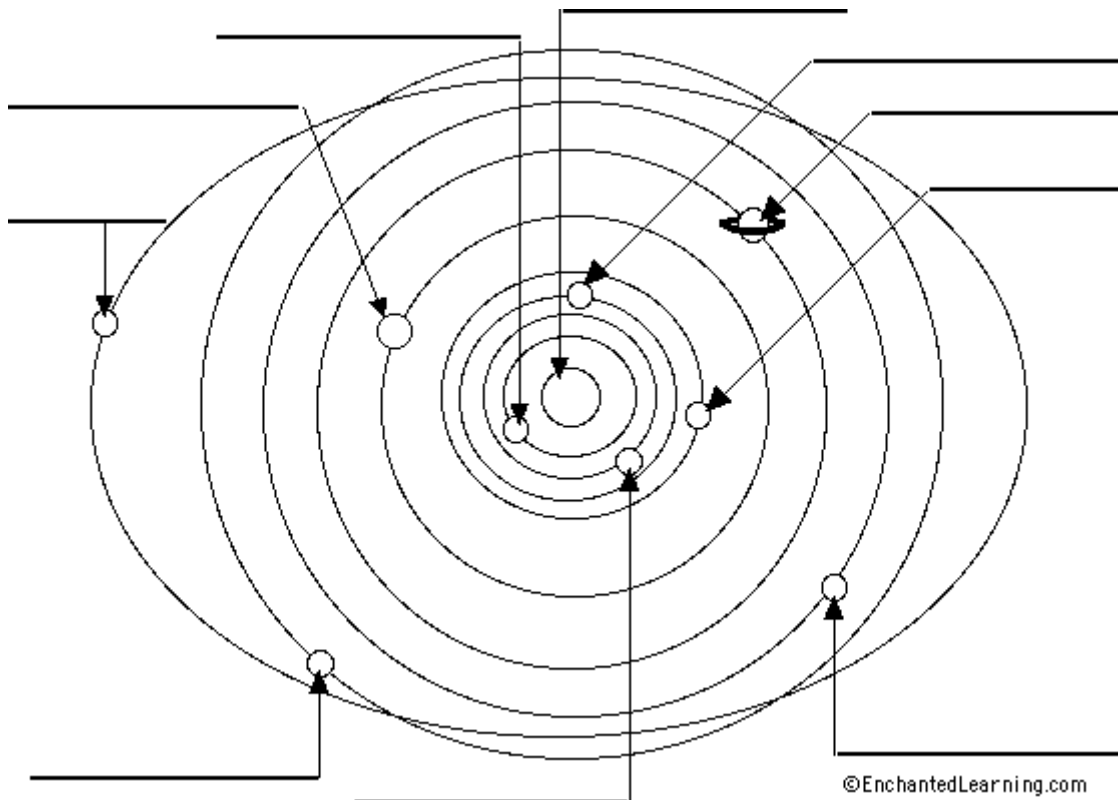

Read a paragraph and answer:

What is the solar system? It is our Sun and everything that travels around it. Our solar system is elliptical in shape. That means it is shaped like an egg. The Sun is in the center of the solar system. Eight planets and their moons, comets, asteroids, and other space objects orbit the Sun. The Sun is the biggest object in our solar system. Astronomers think the solar system is more than 4 billion years old.

- What is Solar System made up?
- How many planets are there? How do they move?
- How old is Solar System?

THE SOLAR SYSTEM: DICTATION AND COMPETITION

We can organize a special dictation. The students have twenty sentences with some gaps and they have to fill the gaps listening to the language assistant. Each sentence describe an object or a phenomenon and they have to guess it.

For example, the students get this sentence:

It is situated..... and Mars. The of the planet is ...

After listening to the language assistant they can write:

It is situated between Venus and Mars. The name of the planet is ...

And finally they can guess the right word: THE EARTH.

We can organize this as a competition so the winners will be those who get the answers first. The winners have to read the full sentence in loud voice; in this way we practise three skills: listening, writing and reading. The following link shows you twenty sentences and their answers: dictation and competition.

SOLUTIONS

1. It is situated between Venus and Mars. The name of the planet is.....(The Earth)
2. The seasons are caused by one of the movements of the Earth. It is called... (revolution).
3. When the Earth passes between the Sun and the Moon that is a.... (lunar eclipse).
4. Its size is similar to the Earth but its atmosphere is full of clouds and so it is the hottest planet in the Solar System (Venus).

5. The Moon makes one complete orbit around the Earth and it lasts..... (29,5 days or a month).
6. They are big rocky bodies moving around the planets. They are called..... (satellites or moons).
7. Its surface is covered in craters and it is the smallest planet in the Solar System. (Mercury)
8. The change of temperature throughout the year is caused by revolution and also by.... (the slant of the Earth axis).
9. It is a group formed by the Sun, the planets and other bodies. It is... (the Solar System).
10. If you can't see the Moon because the illuminated face is on the other side, then it's ... (New Moon)
11. They orbit the Sun on a very large trajectory and they often show a tail. (Comets)
12. They are rocky bodies and most of them are between Mars and Jupiter. (Asteroids belt)
13. It is a body which lights and heats the Earth (Sun).
14. It was the ninth planet but now it isn't because of its small size and its excentric orbit. (Pluto)
15. It is a planet and it is situated very close to Mercury. (Venus)
16. It's midday and a shadow covers the Sun and it disappears. What happens? It's an (eclipse)
17. If you have a clear sky you can see many points of light at night. They are called... (stars).
18. It is the fourth planet in the Solar System and it's often called the red planet. (Mars)
19. It looks like a planet but it isn't. It is covered in craters and we can see it easily from the Earth. (Moon)
20. You can see our natural satellite as a completely illuminated circle. That is ... (full moon).

SENTENCES TO PLAY "DICTATION AND COMPETITION".

1. It is situated and Mars. Theof the planet is_____
2. The are caused by one of the of the Earth. It is called_____
3. When the..... passes between the and the Moon that is a _____
4. Its size is the Earth but its atmosphere is full of clouds and so it is the in the Solar System: _____.
5. The makes one complete the Earth and it lasts_____
6. They are big bodies moving around the They are called_____
7. Itsis covered in craters and it is the planet in the Solar System: _____
8. The change of throughout the year is caused by and also by _____.
9. It is a by the Sun, the planets It is_____.
10. If you can't see thebecause the is on the other side, then it's _____.
11. They orbit the Sun on a trajectory and they oftena tail: _____.
12. They are bodies and most of them are and Jupiter: _____
13. It is a body which and heats the : _____.
14. It was the but now it isn't because of its smalland its excentric orbit: _____
15. It is a and it is situated very Mercury: _____
16. It's and a shadowand it disappears. What happens? It's an _____
17. If you have a clearyou can see many of light at They are called_____.
- 18 It is the planet in the Solar System and it's often called the: _____.
- 19 It looks like a planet but..... It is covered in craters and we can from the Earth: _____
- 20 You can see ouras a completely illuminated That is _____.

1 Jupiter



2 Saturn



3 The Moon



4 The Sun

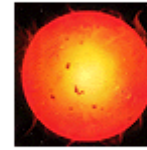

1 Jupiter

2 Saturn

3 The Moon

4 The Sun

5 Mercury

6 Pluto

7 Halley's Comet

8 Venus

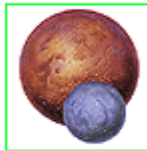

5 Mercury

6 Pluto

7 Halley's Comet

8 Venus

9 Uranus

10 Mars



9 Uranus

10 Mars

Planet-Tac-Toe

This activity can be used in conjunction with the StarChild Level 1 Solar System information on Planets

Objectives:

1. Identify the planets and their relationship to the Sun
2. Comprehend and follow verbal directions
3. Reinforce correct usage of the comparative and superlative cases
4. Use technology to reinforce reading comprehension skills

Materials:

- paper for students to draw planet-tac-toe boards
- pencils
- pennies, poker chips, torn pieces of colored paper, etc. to use as game markers

Procedure:

This activity is designed for use after students have become familiar with the names and characteristics of the eight planets in our solar system. Students should be directed to the appropriate sections of the StarChild site and instructed to read/study the information supplied there about each of the planets. Remind students that the "Did You Know?" and "The Facts" sections also contain important information. Once students are comfortable with their knowledge of the planets, they are ready to play Planet-Tac-Toe. Instruct students to draw a typical tic-tac-toe board. Each of the nine spaces should be filled in with the name of a different planet and the Sun. The arrangement of names is a student decision. The planet names can be written on the chalkboard for students to copy to insure correct spelling. The students will then cover the name of the solar system object that fits the teacher supplied description. The criterion for "winning" can be changed from game to game, for example, the first to cover three in a row vertically, horizontally or diagonally; the first to cover all planet names; the first to cover a plus sign.

Sample Teacher Clues:

1. This planet is the largest of all. (Jupiter)
 2. This planet has more rings than all the others. (Saturn)
 3. This planet has the fastest revolution around the Sun. (Mercury)
 4. Some of the solar systems deepest valleys are found here. (Mars)
 6. Most of this planet is covered by water. (Earth)
 7. This planet is closest to Earth. (Venus)
 8. Only one planet is smaller than this one. (Mercury)
 9. No other planet is hotter than this one. (Venus)
 10. This planet has one more moon than Earth. (Mars)
 11. The energy from this body provides light to the Earth. (Sun)
 12. Only Jupiter is larger than this planet. (Saturn)
 13. This planet is the best place for humans to live. (Earth)
 14. This planet is the smallest. (Mercury)
 15. Only Pluto is ever farther from the Sun than this planet. (Neptune)
 16. This planet is more tilted than any other. (Uranus)
-

**Solar System:
Cloze Activity
Fill in the blanks below.**

Word Bank:

asteroid	ecliptic	Earth
gaseous	moons	center
Mercury	planets	inner
rock	Jupiter	Solar System
Sun	Mars	Pluto

Our _____ consists of the sun, eight _____ and a dwarf planet (and their moons), an _____ belt, and many comets and meteors. The Sun is the _____ of our Solar System. The planets, their moons, the asteroids, comets, meteoroids and other rocks and gas all orbit the _____.

The planets that orbit the sun are (in order from the Sun): _____, Venus, Earth, Mars, _____ (the biggest planet in our Solar System), Saturn (with large, orbiting rings), Uranus, Neptune, and Pluto (a dwarf planet). A belt of asteroids (many minor planets made of rock and metal) orbits between _____ and Jupiter. These objects all orbit the Sun in roughly circular orbits that lie in the same plane, called the _____ (_____ is an exception to this; it has an elliptical orbit that is tilted over 17° from the ecliptic).

The _____ planets (those planets that orbit close to the Sun) are quite different from the outer planets (those planets that orbit far from the Sun). The inner planets are Mercury, Venus, _____, and Mars. They are relatively small, composed mostly of _____, and have few or no moons. The outer planets are Jupiter, Saturn, Uranus, Neptune, and Pluto (a dwarf planet). They are mostly huge, mostly _____, ringed, and have many _____ (again, the exception is Pluto which is small, rocky, dwarf planet with one moon).

Glossary

ASTEROID

A rocky space object that can be a few feet wide to several hundred miles wide. Most asteroids in our solar system orbit in a belt between Mars and Jupiter.

ASTRONAUT

A person who travels in space.

COMET

A big ball of dirty ice and snow in outer space.

GALAXY

A giant collection of gas, dust, and millions or billions of stars.

METEORITE

A piece of stone or metal from space that falls to Earth's surface.

PLANET

An object that orbits a star.

SATELLITE

An object that moves around a planet. There are natural satellites such as moons and there are man-made satellites.

UNIVERSE

The huge space which contains all of the matter and energy in existence.